

SECTION A-A

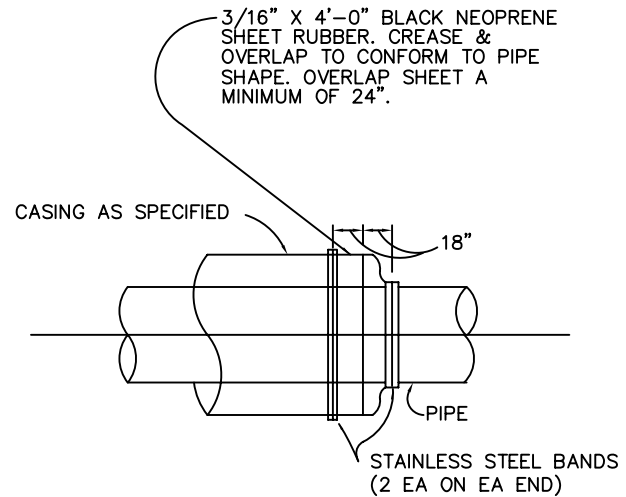
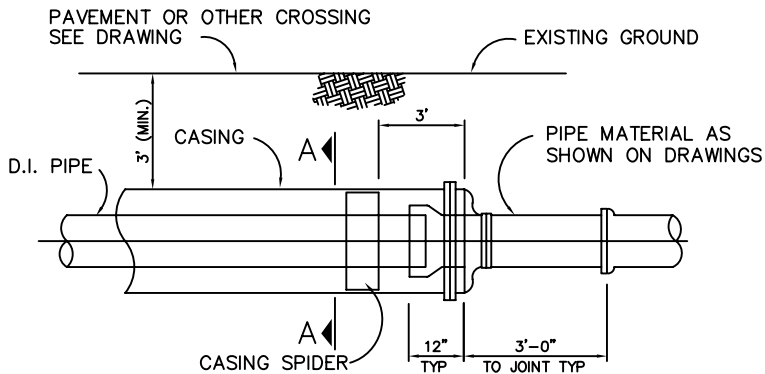

CASING END SEAL  
(TYPICAL EACH END)

DATE: 7/1/93	REVISIONS		STANDARD DETAIL	LEXINGTON COUNTY JOINT MUNICIPAL WATER AND SEWER COMMISSION
	09/2005	GENERAL		
SCALE: NTS			DRY BORE AND JACK ENCASEMENT AND CARRIER DETAIL	FILE NO. WL015